

BUTTERFLY VALVES

R&D Multiple's Butterfly Valves have been very commonly used in various applications all over the globe for past 3 decades. Irrespective of sizes, pressure ratings, fluids handled, type of operators etc. our Butterfly Valves are the most preferred choice of the discerning customers. We have also kept our valves in tune with the latest technological advancements in materials, manufacturing, pattern making & foundry & operators fields. This has enabled us to offer valves from 50mm. to 3600mm. sizes in pressure ratings 6 to 40bar, in Cast / Fabricated constructions in Cast Iron, Carbon & Alloy Steels, Stainless Steels & also Rubber-lined variety. The types of operators offered are Manual, Electrical, Pneumatic, & Electro-Hydraulic. We also supply large Hydraulically operated Pump discharged valves (HOPD). In short; we provide techno-commercially best solution to any installation in which use of Butterfly Valves is envisaged.

www.rdmultiples.com

D/F BUTTERFLY VALVE WITH MANUAL GEARBOX

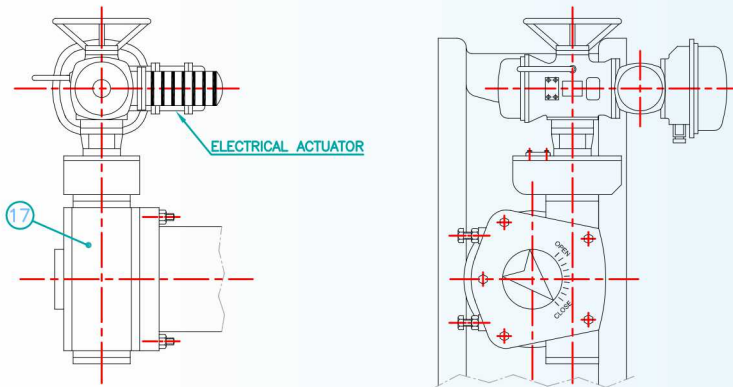
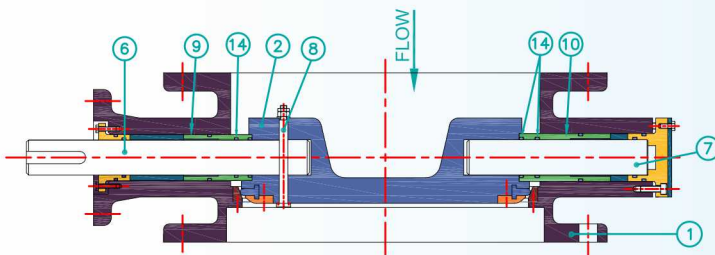
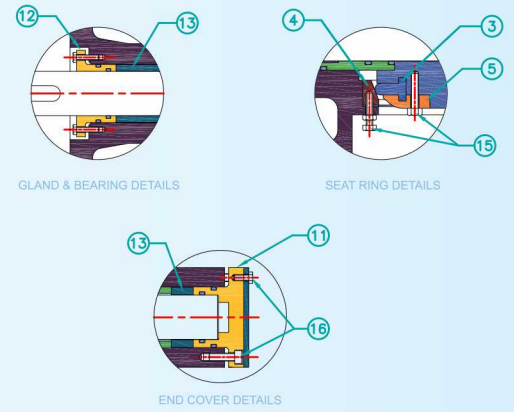
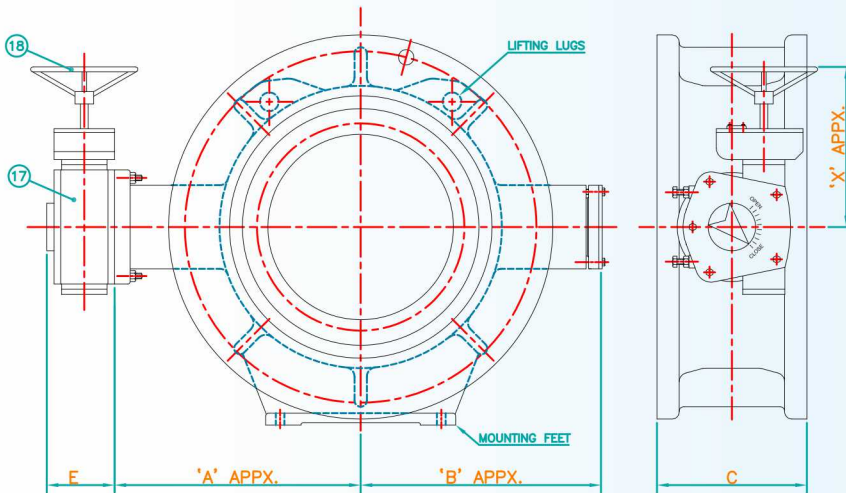

No.	Party Name	Material
1.	BODY	CAST IRON IS 210 GR. FG 260
2.	DISC	SG IRON IS 1865 GR. 500/7
3.	DISC SEAL RING	NITRILE RUBBER
4.	BODY SEAT RING	STAINLESS STEEL AISI 304
5.	CLAMPING RING	STAINLESS STEEL AISI 304
6.	LONG SHAFT	STAINLESS STEEL AISI 410
7.	STUB SHAFT	STAINLESS STEEL AISI 410
8.	SHEAR PIN	STAINLESS STEEL AISI 410
9.	LONG BUSH	STEEL BACKED PTFE
10.	STUB BUSH	STEEL BACKED PTFE
11.	END COVER	SG IRON IS 1865 GR. 500/7
12.	GLAND BUSH	MILD STEEL
13.	SPACER	STEEL WITH ELECTROLESS NICKEL PLATING
14.	'O' RING	NITRILE RUBBER
15.	INTERNAL HARDWARE	STAINLESS STEEL AISI 304
16.	EXTERNAL HARDWARE	CARBON STEEL IS 1367 CL 4.6 / 4
17.	GEARBOX	QUARTER TURN WORM GEAR TYPE
18.	HANDWHEEL	MILD STEEL

VALVE Size	'A' Appx.	'B' Appx.	'C'		'E'	'X' APPX.
			EN:593	AWWA C-504		
65	140	125	112	127	48	180
80	145	130	114	127	48	180
100	160	135	127	127	48	180
125	180	160	140	127	48	180
150	195	175	140	127	48	180
200	240	190	152	152	48	180
250	265	220	165	203	62	240
300	325	270	178	203	68	285
350	345	290	190	203	83	300
400	380	330	216	204	75	305
500	450	380	229	203	84	320
550	485	415	248	203	115	370
600	495	440	267	203	115	370
700	550	490	292	271	123	395
750	595	540	305	305	160	500
800	650	590	318	305	151	410
900	710	640	330	305	151	410
1000	740	680	410	305	204	514
1100	820	760	440	330	204	514
1200	870	790	470	381	216	439
1300	920	860	500	381	270	640
1400	1050	960	530	381	305	640
1500	1110	1070	565	381	305	955
1600	1220	1120	600	432	305	955
1800	1305	1230	670	457	305	955
2000	1390	1320	760	483	355	1060
2200	1510	1440	760	534	355	1060
2400	1615	1590	760	534	390	1220
2500	1670	1600	--	585	390	1220
2600	1775	1680	--	610	390	1220

ELECTRIC ACTUATOR WITH GEAR BOX OPERATOR.

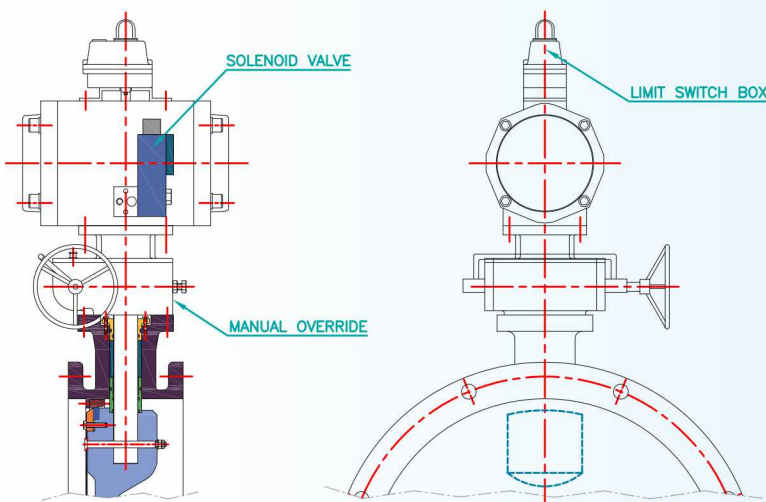

ROTARY PNEUMATIC ACTUATOR WITH MOR LINEAR ACTUATOR WITH MOR OPTION AVAILABLE.

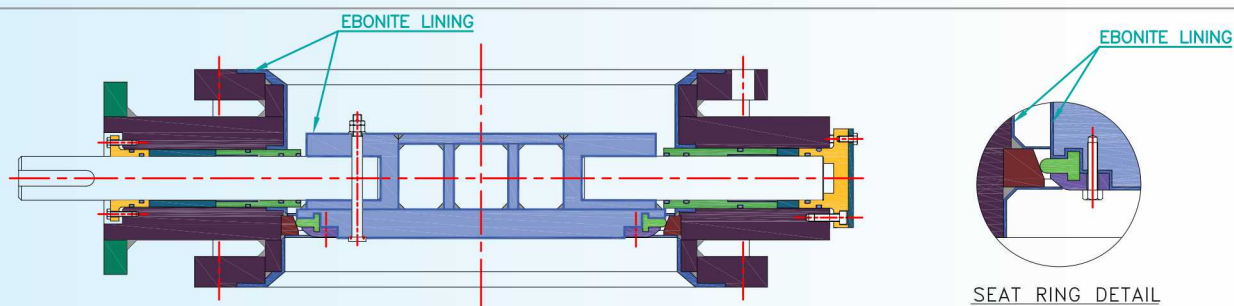

RUBBER LINED D/F BUTTERFLY VALVE

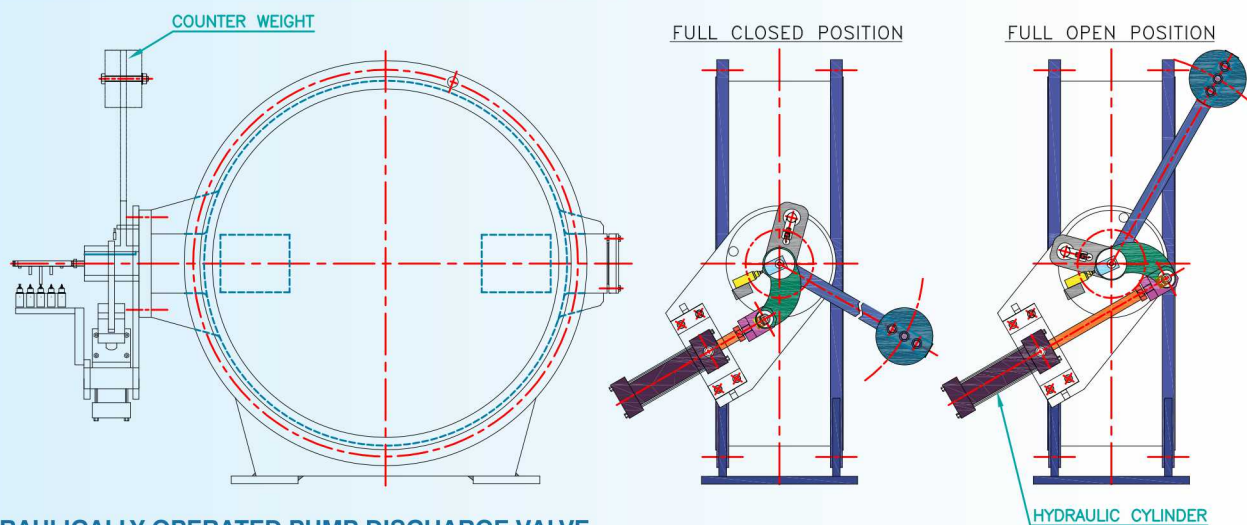

HYDRAULICALLY OPERATED PUMP DISCHARGE VALVE

SALIENT FEATURES OF FLANGED BUTTERFLY VALVES

- Sturdy & robust construction.
- Disc assembly perfectly centered & secured in valve body bore.
- Seat Ring cone finished in-situ.
- Flow through disc ensuring minimum pressure drop.
- Secured Disc-Shaft Connection.
- Cast & Fabricated constructions possible.
- Compliance with: IS 13095, AWWA C504, BS EN 593 standards.
- Manual, Electrical, Pneumatic & Electro-Hydraulic Operators.
- NDE side thrust arrangement.
- Shaft seals comprising of elastomeric 'O' rings & 'Lip seals'.
- Disc seal secured in - between machined grooves in disc & clamping ring making it completely washout-proof.
- Perfection of alignment of components, fine finishing of rubbing surfaces, controlled seal dimensions ensure very smooth operation & less operating torque requirement.
- Electrical / Pneumatic actuator drives optionally available.
- Accessories like Head-stock & Extn. Shafting, Disc Locking options available.

SPECIAL FEATURES : FLANGED BUTTERFLY VALVES

- Flow through disc ensuring minimum pressure drop.
- Disc locking arrangement option available.
- Wide options in : (A) Materials of construction, (B) End Connections, (C) Face to face dimns.
- Shaft bearings not wetted by fluid handled ensuring low frictional torque & long bearing life.
- Concentric, Single, Duo & Tri-eccentric constructions offered for appropriate applications.
- Endurance Life Cycle Testing Carried out for prototype sample sizes as per AWWA C-504 covering all the range of manufacturing.
- Installation with vertical or horizontal shaft possible.

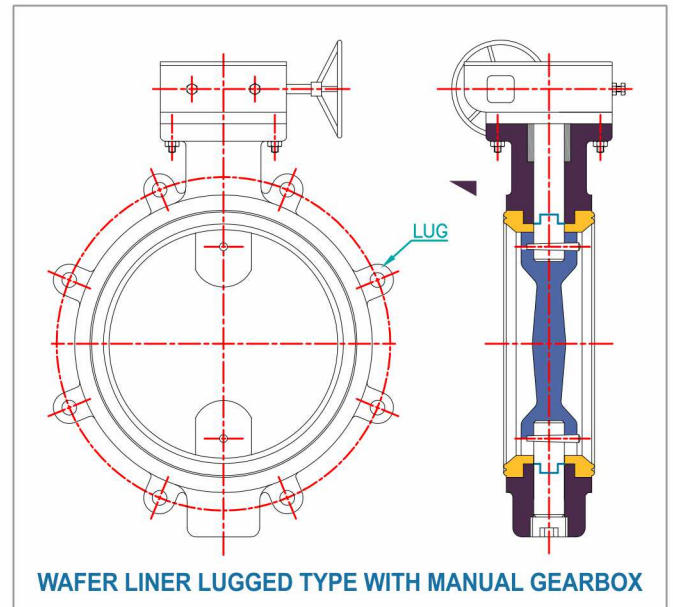
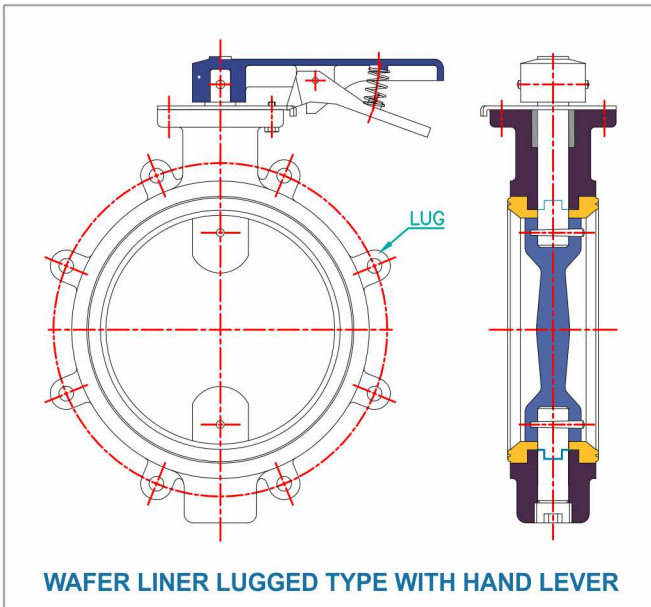

SALIENT FEATURES : LINER VALVES

- Liner locked in precision machined grooves in valve body.
- Sealing ribs on end faces with enough protrusion to ensure drop-tight end face joints.
- Sturdy & long shaft bearings ensuring precise rotation of the disc assembly in the body.
- Double Shaft seal which precludes leakage possibility.
- Sturdy Disc-shaft connection.
- Robust backlash-free Hand Lever mechanism without the possibility of over-travel due to provision of in-built, positive travel limit stops.
- Electrical / Pneumatic actuator drives optionally available.

SPECIAL FEATURES : LINER VALVES

- Optimized liner dimensions ensuring efficient sealing performance.
- Critically controlled interference between the rubber liner & the Disc sealing surface ensuring leak-tightness & lower operating torque at the same time leading to long seal life.
- Stainless Steel Investment cast Disc as a standard scope of supply.

NOTES: 1) All dimensions are in mm unless otherwise specified.

2) Views and dimensions are typical & illustrative. They may change with design modifications.

3) For larger sizes / HOPD dimensions & special requirements, contact our Marketing Dept.

4) Pressure Ratings as per PN 6 / 10 / 16 / 25 & class ratings as per AWWA C-504.



R&D MULTIPLES (METAL-CAST) PVT. LTD.

Head Office : 106, United Industrial Estate, Mogul Lane,
Mahim, Mumbai 400 016, Maharashtra, India.
Tel : 4004 4425/26/27/28/29

Plant 1 : A-1/17, GIDC, Pardi - 396 125,
District Valsad, Gujarat.

Plant 2 : Survey No. 304, Village Balda,
Pardi - 396 125, District Valsad, Gujarat.

Engineering Division Office : C2-403, Saudamini Complex,
Srl. No. 101/1, Bhusari Colony, Paud Road, Kothrud, Pune 411 038, India.

E-mail : mumbai@rdmultiples.com

Company & Corporate information, Accreditations Dealer's Stamp